

729 Boylston Street
Boston, MA 02116

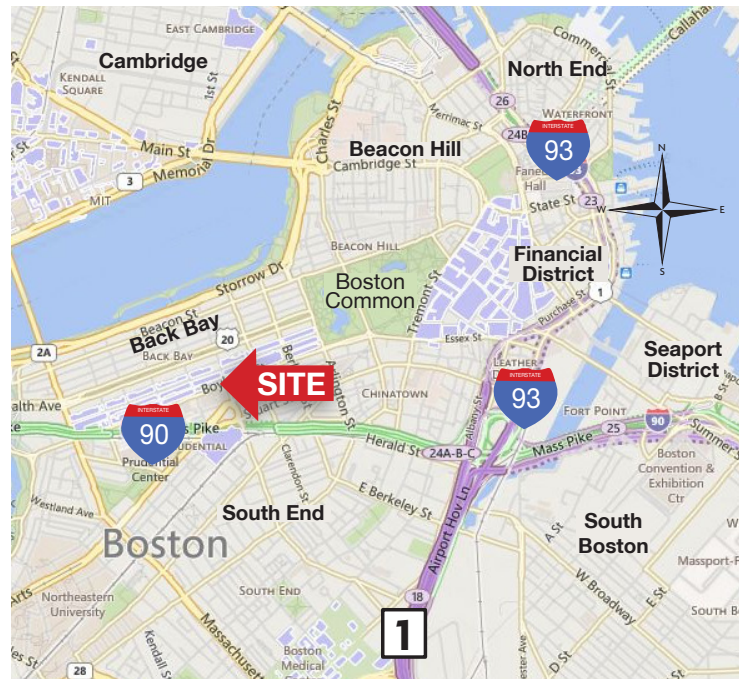

DESCRIPTION

- Fully leased
- Street level
- Located in Boston's Back Bay, the 2nd largest office sub-market in New England, with over 16 million SF of office space
- Across from The Mandarin Oriental Hotel, the Prudential Center and Eataly
- 1 block from MBTA Green Line Copley T stop
- 1 block from the Newbury Street shopping district



FOR MORE INFORMATION

Evan Eisenhardt, SVP - Leasing | eisenhardt@linearretail.com | Office 781.202.3536 | Cell 617.807.0577

729 Boylston Street, Boston, MA

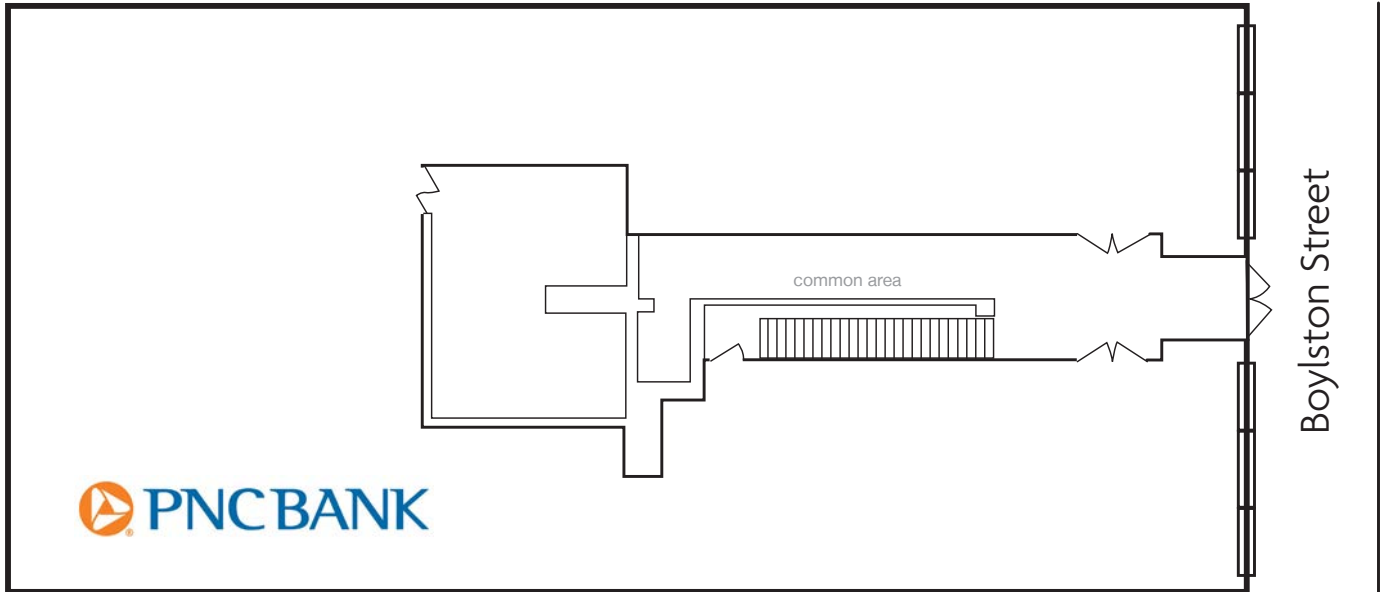

MARKET DATA

- 3 blocks from 176,480 SF Hynes Convention Center
- Back Bay is the 2nd largest office sub-market in New England with over 16 million SF of office space
- MBTA Green Line Copley T stop averages over 14,000 daily entrances, top 10 of all stations in Boston
- Back Bay has over 7,000 hotel rooms covering 50% of the demand in the city
- 3.6 million SF of mixed-use office and retail space in the Prudential Center

DEMOGRAPHICS

Radius	Residential Population	Average HH Income	Daytime Population
.50 mile	25,049	\$183,490	70,444
.75 mile	60,060	\$151,120	105,800
1 mile	105,265	\$141,060	183,836



FOR MORE INFORMATION

Evan Eisenhardt, SVP - Leasing
eisenhardt@linearretail.com | 781-202-3536

729 Boylston Street, Boston, MA

DARTMOUTH STREET

NEWBURY STREET

BOYLSTON STREET

BLAGDEN STREET

EXETER STREET

RING ROAD

FAIRFIELD STREET

GLOUCESTER STREET

HEREFORD STREET

DALTON STREET

Stores and Businesses: ENZO & CO, Hairo, THE CAPITAL B-UR-G-ER, THE TIE BAR, credo, American Bar & Grill, benefit, BEN & JERRY'S, Levain BAKERY, INTERMIX, Stephanie's on Newbury, sweetgreen, CHARLES MARK HOTEL, B.GOOD FOOD WITH ROOTS, at&t, Bank of America, Boston Public Library, WESTIN HOTELS & RESORTS, Sorrelina, COURTYARD Marriott, TED BAKER LONDON, Timberland, ANTHROPOLOGIE, allbirds, ROTHY'S, Serafina, NIKETOWN, ZARA, EUROPEAN WAX CENTER, PIATTINI, CVS pharmacy, DUNKIN' DONUTS, SITE, PNC BANK, LENOX, city table, Lindt, SOLAS, star market, Starbucks, Crate&Barrel, Ace Louie's, porto, THE SHOPS AT PRUDENTIAL CENTER, Aritzia, Barnes & Noble, Canada Goose, Kate Spade, lululemon, Madewell, MAC Cosmetics, Oakley, Pandora, Pelaton, Sephora, Sunglass Hut, Swarovski, Tesla, Under Armour, Warby Parker, FIRST REPUBLIC BANK, MANDARIN ORIENTAL, CHASE, EATALY, Amorino, deWolfe leather goods, RE.VOLVE, Fidelity, MATTRESS FIRM, Apple, Walgreens, Tracksmith, Johnny Cupcakes, G2 SALON, pressed juicery, PAVEMENT, LINEAR RETAIL RED WHITE JAPANESE YEAST CUISINE 1,469 SF Available, ROYAL ROBBINS, LADY M CONFECTIONS, MOTHER JUICE, Viselli VS Santoro salon, FRED PERRY, MINISTRY OF SUPPLY, Sonsie, Madswell, Champion, BOSTON ARCHITECTURAL COLLEGE, THE NORTH FACE, TJ-maxx, DILLON'S, THE CAPITAL GRILLE, Sheraton.



FOR MORE INFORMATION

Evan Eisenhardt, SVP - Leasing
 eeisenhardt@linearretail.com | 781-202-3536